

# TRI-150R Adjustable Tripod

## Product Overview

The TDK RF Solutions TRI-150R tripod is designed specifically for mounting antennas and video cameras in EMC test environments. The tripod is constructed of durable, non-conductive, commercial grade fiberglass and plastic that provide the necessary stability while allowing for portability.

The tripod mast easily adjusts from 100 cm to 150 cm in height, and supports equipment up to 45 kg. The sturdy, fixed-length fiberglass legs feature adjustable foot pads to accommodate uneven floor surfaces. The legs fold inward for storage or transportation between test sites.

The tripod also features an integrated level to allow quick and accurate positioning.

The TRI-150R is available with a variety of antenna and video camera mount adapters to meet your requirements.

## Application

- Antenna or video camera mounting

## Features

- 1/4 - 20 screw mount adapter (standard)
- Supports up to 45 kg (100 lbs.)
- Integrated level for accurate positioning
- Custom antenna mount adapters available
- Custom video camera mount adapters available



**The TDK RF Solutions TRI-150R Tripod is specifically designed for EMC test environments and can support up to 45 kg.**

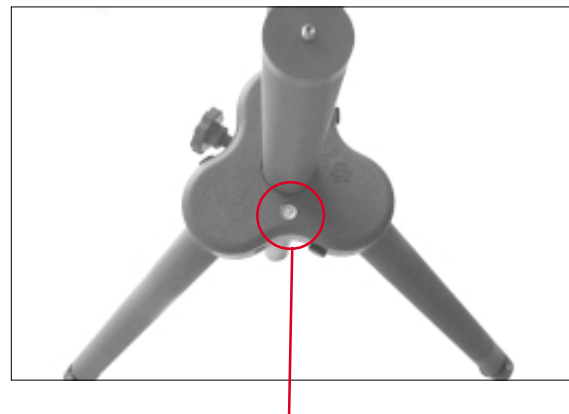

**The TDK TRI-150R's built-in level and independently adjustable feet simplify positioning on uneven surfaces.**

# TRI-150R Adjustable Tripod

## Mechanical Specifications

Dimensions:	
Extended Height:	150 cm (59 in.)
Collapsed Height:	100 cm (39.4 in.)
Base Diameter:	100 cm (39.4 in.)
Weight:	11 kg (24 lbs.)
Construction:	Fiberglass and plastic
Finish:	Preventive water absorption seal

## Ordering Information

Product:	Tripod
Model Number:	TRI-150R
Warranty:	1 year

**To place an order or to learn more about the TDK RF Solutions products that best meet your needs, contact your TDK sales representative:**

### TDK Electronics Europe

TDK House, 5-7 Queensway  
Redhill, Surrey RH1 1YB  
United Kingdom  
Phone: +44-(0)1737-781372, Fax: +44-(0)1737-781360  
E-Mail: [chambers@tdk.de](mailto:chambers@tdk.de)  
World Wide Web: [www.tdk-components.de/chambers](http://www.tdk-components.de/chambers)

TOTAL RF EXPERTISE™



[www.tdkrfsolutions.com](http://www.tdkrfsolutions.com)

To learn more about TDK RF Solutions' wide range of innovative products and services visit [www.tdkrfsolutions.com](http://www.tdkrfsolutions.com)

© Copyright 2001–2002 TDK RF Solutions Inc. All rights reserved. Specifications subject to change without notice.

DSTRI150R041902